

DISCOVER
THE
BEAUTY OF
ENGINEERING



ALUMINIUM WINDOWS

PRESENTING ETERNIA ALUMINIUM WINDOWS



Hindalco - one of the leading players in aluminium the world over - brings to you Eternia Windows: where beauty and engineering come together seamlessly.

Made from aluminium - the 100% green and recyclable metal - Eternia is an ideal choice to adorn your home with.

Eternia Windows are fabricated and installed by a team of experienced Hindalco-licensed fabricators to help you give your designs the perfect look. Eternia Windows also come in a wide range of colours and finishes to suit your every need. Every

Eternia Window is made using precision technology imported from Italy and is completely customisable to give your home that flawless finish. Bring home an Eternia Window today and start a relationship for life.

ETERNIA ADVANTAGES

- Made from Hindalco quality aluminium extrusions in 6063 T6 to ensure high strength and durability.
- Superior Italian design, quality hardware and accessories for long-lasting trouble-free performance.
- Rust-free and requires no maintenance.
- Made from virgin aluminium to provide superior anodizing and coating properties.
- Customised solutions, fabrication and installation by experienced fabricators.
- Specialized Italian punching machine and tools for precision, consistency and superior finish.
- Smooth, noiseless and hassle-free operations.
- Limitless colours and textures: Anodized, Powder-coated, PVDF & Wood finish.
- Life of the aluminium window and retention of colour on exposure to sunlight - highest in the category.
- Suitable for all-weather conditions.





ALUMINIUM WINDOWS

CASEMENT SYSTEMS

ET510 C

ET410 C

ET260 C

SYSTEM & FEATURES

CASEMENT SYSTEMS

ET510 C

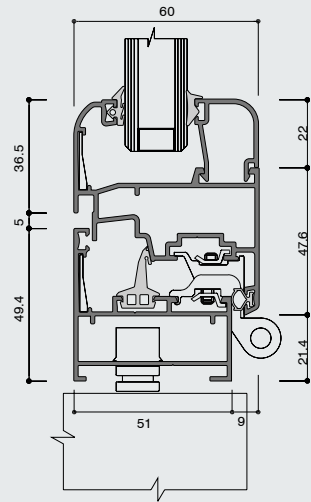

Heavy

- External & Internal Opening, Tilt & Turn, Pivot, Top Hung with fixed frame option.
- Range of glass/panel thickness from 4 mm to 25 mm.
- Option of double-glazing laminated glass for excellent sound insulation.
- Glazing from inside for security.
- Mechanically-strong Corner & 'T' joints.
- Seal type (Air/Water): internal & external overlapping central gasket & rabbet (EPDM). Co-extruded for weather resistance (-30°C to 50°C).
- Single to multi-point locking system.
- Insect Screen option available.
- Limits of employment: 2510 mm height.

Medium

- External & Internal Opening, Tilt & Turn, Pivot, Top Hung with fixed frame option.
- Range of glass/panel thickness from 4 mm to 20 mm.
- Option of double-glazing laminated glass for excellent sound insulation.
- Glazing from inside for security.
- Seal type (Air/Water): internal & external overlapping central gasket & rabbet (EPDM). Co-extruded for weather resistance (-30°C to 50°C).
- Single to multi-point locking system.
- Insect Screen option available.
- Limits of employment: 2200 mm height.

SYSTEM & FEATURES

CASEMENT SYSTEMS

ET410 C

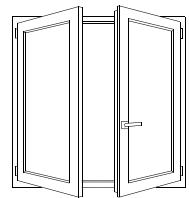
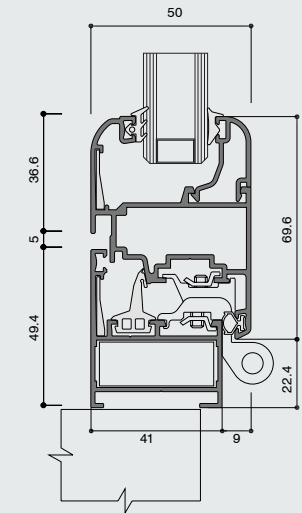

INTERNAL OPENING

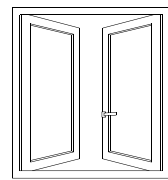

EXTERNAL OPENING

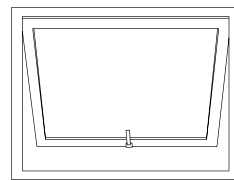

TOP HUNG

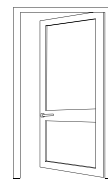

DOOR –
EXTERNAL OPENING

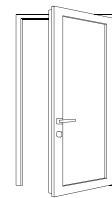

DOOR –
INTERNAL OPENING

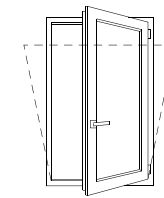

TILT & TURN

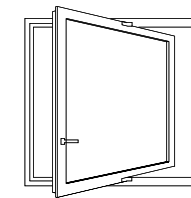

PIVOT

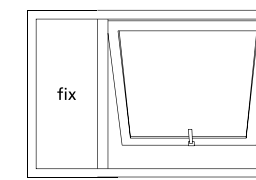

TOP HUNG
+ FIXED FRAMES

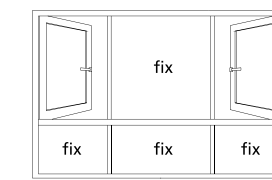

EXTERNAL OPENING
+ FIXED FRAMES

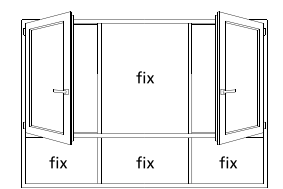

INTERNAL OPENING
+ FIXED FRAMES

SYSTEM & FEATURES

CASEMENT SYSTEMS

ET260 C

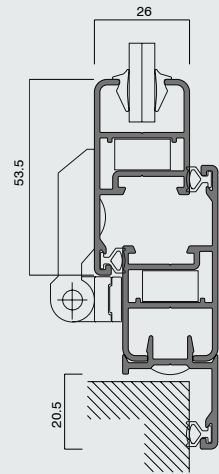

Utility

- External & Internal Opening.
- Maximum thickness of glass/panel: 8 mm.
- Option to use as Insect Screen in ET410C & ET510C series.
- Seal type (Air/Water): internal & external overlapping (EPDM).
- Limits of employment: 1375 mm height.

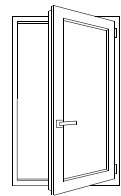

INTERNAL OPENING

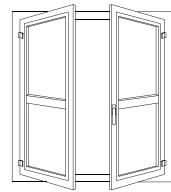

EXTERNAL OPENING

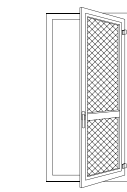
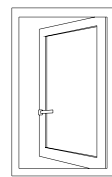

INSECT SCREEN





SLIDING SYSTEMS

ET350 S

ET280 S

ET230 S

Heavy

- Available in 2-track & 3-track, along with fixed frame option.
- Double & single glazing option.
- Range of glass/panel thickness 6 mm to 26 mm.
- Single roller capacity: 100 kg/shutter and adjustable double roller capacity: 150 kg/shutter.
- Mechanically-strong Corner joints.
- Seal type (Air/Water): Wool pile - EPDM gasket.
- Option with heavy-duty shutter for high-rise buildings and larger dimensions.
- Provision for Insect Screen.
- Automatic, manual & multi-point locking system.
- Limits of employment: 2300 mm height.

SYSTEM & FEATURES

SLIDING SYSTEMS

ET350 S

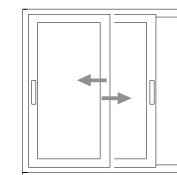
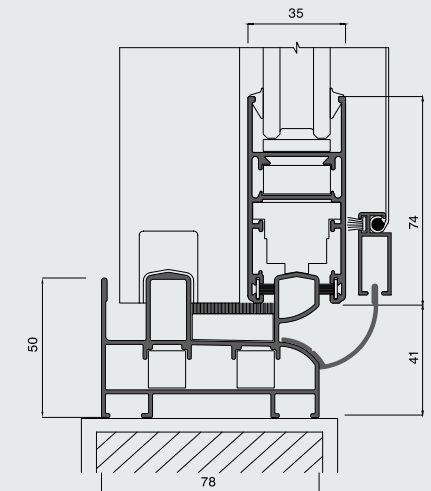

2 TRACKS + 2 SHUTTERS

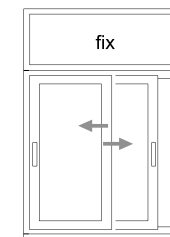

2 TRACKS + 2 SHUTTERS + FIXED FRAME

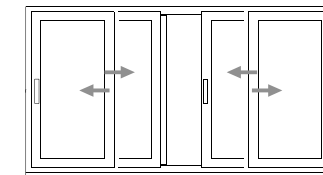

2 TRACKS + 4 SHUTTERS

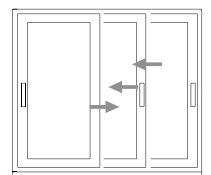

3 TRACKS + 3 SHUTTERS

SYSTEM & FEATURES

SLIDING SYSTEMS

ET280 S

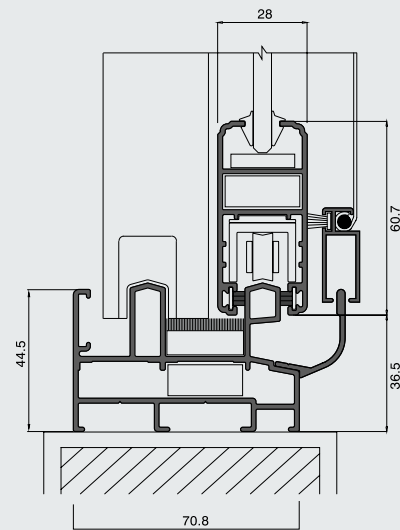

Medium

- Available in 2-track & 3-track along with fixed frame option.
- Double and single glazing option.
- Range of glass/panel thickness: 6 mm to 20 mm.
- Single roller capacity: 70 kg/shutter and adjustable double roller capacity: 90 kg/shutter.
- Mechanically-strong Corner joints.
- Option with heavy-duty shutter for high-rise buildings and larger dimensions.
- Wool pile – EPDM for air-resistance and water-resistance.
- Provision for Insect Screen.
- Limits of employment: 2150 mm height.

Sleek

- Available in 2-track & 3-track, along with fixed frame option.
- Maximum thickness of glass/panel: 6 mm.
- Single roller capacity: 30 kg/shutter and double roller capacity: 60 kg/shutter.
- Mechanically-strong Corner joints.
- Wool pile for air-resistance and water-resistance.
- Provision for Insect Screen.
- Limits of employment: 1300 mm height.

SYSTEM & FEATURES

SLIDING SYSTEMS

ET230 S

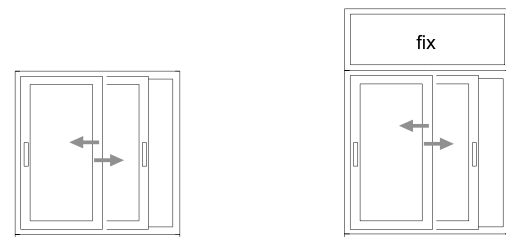
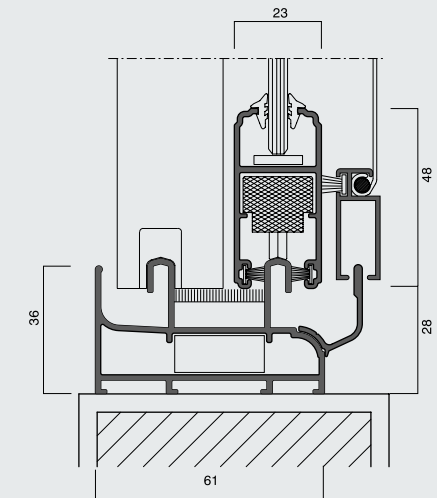

2 TRACKS + 2 SHUTTERS

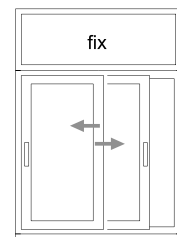

2 TRACKS + 2 SHUTTERS
+ FIXED FRAME

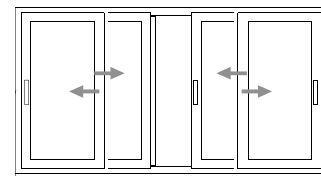

2 TRACKS + 4 SHUTTERS

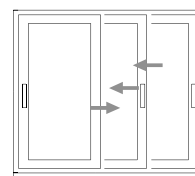

3 TRACKS + 3 SHUTTERS

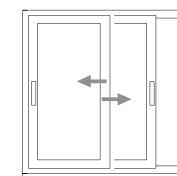

2 TRACKS + 2 SHUTTERS

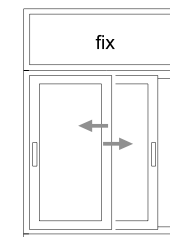

2 TRACKS + 2 SHUTTERS
+ FIXED FRAME

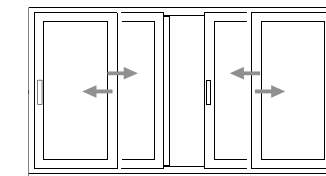

2 TRACKS + 4 SHUTTERS

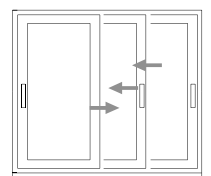

3 TRACKS + 3 SHUTTERS

HARDWARE & ACCESSORIES



At Eternia, we focus on the superior performance of our window systems, which is why when it comes to our hardware, we import the best solutions from Italy. Our range of hardware and accessories comes from reputed European manufacturers, and are recognized as world-class in quality, design and craftsmanship. Our Italian heritage include bold designs and vivid colour schemes, attention to the minutest of detail, emphasis on quality, and a penchant for creative and unique solutions.

- Dedicated accessories for specific functions
- Wide range to choose from
- Available in various RAL colours



MARKETING HEAD OFFICE

Rajendra Pareek

7th Floor, Birla Centurion Pandurang Budhkar Marg, Worli, Mumbai 400 030. India

Tel: +91-22-6662 6666/43/59. Fax: +91-22-2422 7586, 2436 2516

Email: rajendra.pareek@adityabirla.com

REGIONAL OFFICES

North

Nutan Singh

Vandhana, 5th Floor, 11, Tolstoy Marg, New Delhi 110 001.

Tel: +91-11-4220 0200. Fax: +91-11-2372 1595

Email: nutan.singh@adityabirla.com

East

Abhijit Chakraborty

Jeevan Deep Building, 1, Prafulla Chandra Sen Sarani, Kolkata 700 071.

Tel: +91-33-2280 9710, 2288 6135. Fax: +91-33-2288 6139

Email: abhijit.chakraborty@adityabirla.com

West

Ashish Nema

Ahura Centre, 1st Floor, 82, Mahakali Caves Road, Andheri (East), Mumbai 400 093.

Tel: +91-22-6691 7000/31. Fax: +91-22-6691 7070/50

Email: ashish.nema@adityabirla.com

South

Ashok Kumar

Industry House, 7th Floor, 45, Race Course Road, Bangalore 560 001.

Tel: +91-80-4041 6000. Fax: +91-80-2225 3086

Email: ashok.k.kumar@adityabirla.com

